

SHOREMASTER VERTICAL LIFT

- OWNER AND OPERATORS MANUAL -

Model 30866 Or 38966

30866 / Maximum Load 3,000 Pounds - Inside Lift Width 96" (8 ft.)

38966 / Maximum Load 3,800 Pounds - Inside Lift Width 108" (9 ft.)

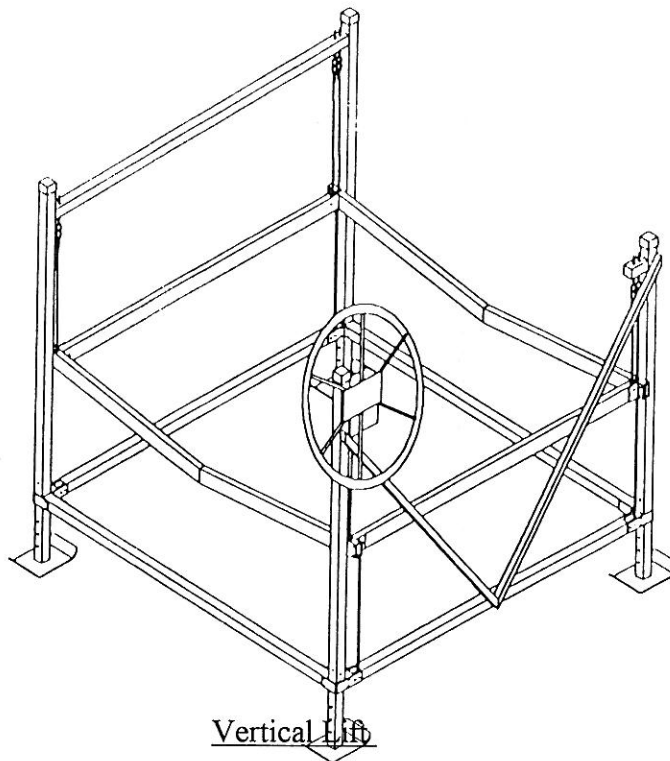

Vertical Lift

Manufactured by ShoreMaster Inc.

Revision No. (1) 2-1-96

ShoreMaster Inc.

1 ShoreMaster Drive - PO Box 358

Fergus Falls, MN 56538-0358

1-800-328-8945

TABLE OF CONTENTS

<u>PAGE</u>	<u>SECTION</u>
3	Introduction
3	Warnings and Safety
4-5	Parts List 30866 & 38966
6-13	Assembly 30866 & 38966 Lifts
14-15	Installation
16-18	Operation -Loading, Raising, Lowering
19	Removal and Storage
20	Service
21	Cable Routing Drawing

INTRODUCTION

ShoreMaster 30866 & 38966 vertical lifts will lift your boat up and out of the water for dockside storage. These lifts are designed to rest on a stable lake bottom. This lift performs well in low water conditions, fluctuating water up to four feet or when your boat requires mooring high out of the water. There are maximum allowable water depths depending on your leg lengths and situation. A properly positioned lift will provide safe, convenient, quick mooring for your boat.

The lift functions by turning the lift hand wheel clockwise to raise the lift. Properly position your boat in the lift and it will raise with the lift rack. The wheel is turned counterclockwise to lower the lift.

Information in this manual is not all inclusive and cannot cover all unique situations. If you have questions about assembly, installation, operation or suitability of this product contact an authorized ShoreMaster dealer or ShoreMaster toll-free 1-800-328-8945.

WARNINGS AND SAFETY

Your **SAFETY** is the most important issue related to this product. It is critical that all assemblers, installers and users read and fully understand the warnings and safety information contained throughout this manual before using this product.

Safety Instructions

Never exceed recommended weight capacity of your lift. The weight of your boat includes the hull, engine, fuel, gear, battery, and added accessories. The dry weight reported by the manufacturer usually includes only basic boat and engine. The boat manufacturers reported weights can be understated by 10 -30%! This is before you add fuel, fluids, batteries, accessories, etc.! Weigh your boat at a certified scale to be absolutely sure of the total weight. You will be lifting 20 - 50% more than the reported dry weight when everything is considered.

- A properly educated or trained person is needed for assembly and installation of this product. Call ShoreMaster if you have questions.
- Wear proper protective clothing and eye wear when assembling or installing lift.
- Do not assemble, install or use this product if items are missing or damaged.
- If fast spin down of wheel occurs do not touch wheel or attempt to stop. Allow your boat to splash into water, it should not damage your boat! Placing hands or feet on spinning wheel can cause broken or cut limbs.
- **WARNING** - Stay clear of lift (facing wheel) while operating. Do not allow anyone on, in or under lift. A cable or lift part failure can cause a sudden drop of boat, resulting in a crushing or falling injury or death!
- Do not allow people on boat when boat is on lift in raised position.
- Do not make alterations or adjustments to lift or accessories when boat is on lift.
- Check cables for frays, corrosion or breaks at least once a month. A cable breaking while boat is in lift could damage boat or lift. Severe bodily injury could also occur.

30866 Or 38966 LIFT PARTS LIST

Before assembly, identify each part. Remove parts from boxes, bags and bundles. Mark each item with the proper part letter (indicated in the left-hand column). This will confirm that all parts are here before beginning assembly and allows you to easily follow the assembly instructions.

****DO NOT CONFUSE SHOREMASTER I.D. STICKERS ALREADY PLACED ON PARTS. THESE LETTERS OR NUMBERS ARE FOR PACKING LIST IDENTIFICATION AND MAY NOT CONFORM TO I.D. LETTERS OR NUMBERS USED IN THIS INSTRUCTION MANUAL.**

30866 & 38966 Winch Box & Bolt Bag:

Tools Needed For Assembly

<u>Part ID</u>	<u>Qty.</u>	<u>Description</u>
AA	1	SM Winch (5000 series)
BB	4	# 11 Blue Caps
CC	1	Wheel to Winch Bolt Kit
DD	1	Cable Guide

2 - 9/16" Combo Wrench
1 - 7/16" Combo Wrench
1 - 3/16" Allen Wrench

Bolt Bag:

- 8 - 3/8" x 1" Hex Bolts (for rack beams)
- 22 - 3/8" x 4" Hex Bolts
- 30 - 3/8" Nuts
- 4 - 3/8" Washers
- 8 - 3/8" x 3 1/2" Pins (for legs & cables)
- 8 - Pin Clips
- 5 - 1/2" Lock Nuts
- 5 - 1/2" Washers

Part A
V Side
Qty 1

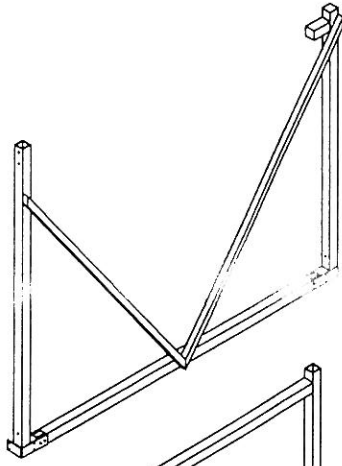

Part B
Reg. Side
Qty 2

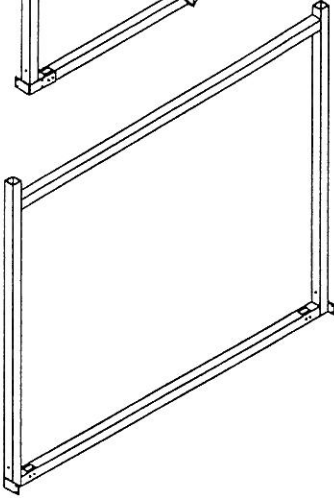

Part C
Leg
Qty 4

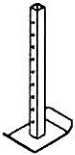

Part D
Bottom Beam
Qty 2

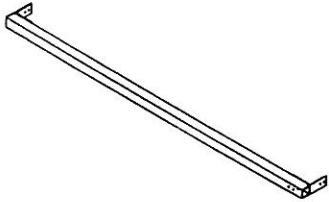

Part E
Left Rack
W/Cables
Qty 1

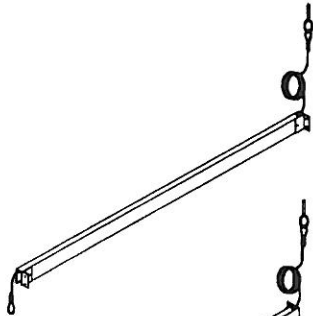

Part F
Right Rack
W/Cables
Qty 1

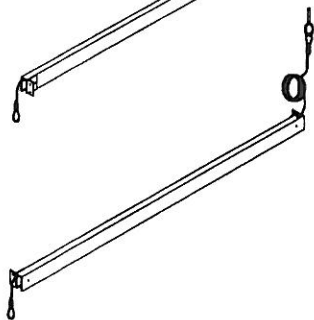

Part G
Rear Rack
W/2 Cables
Qty 1

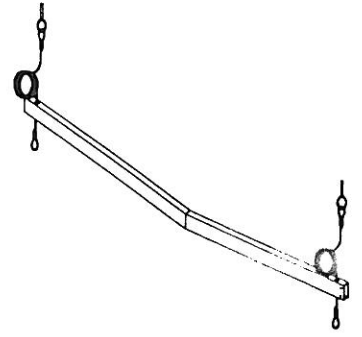

Part H
Front Rack
W/1 Cable
Qty 1

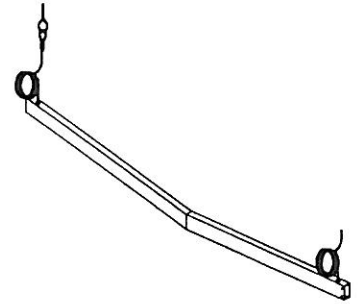

Part I
Wheel
Qty 1

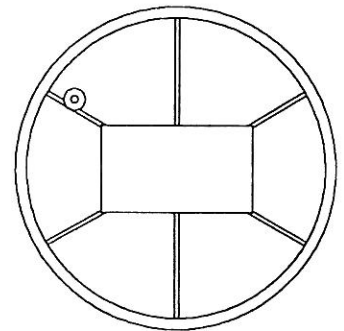

ASSEMBLY OF 30866 OR 38966 LIFT

****Fully read and understand each step before proceeding with that step.**
****Only hand tighten bolts and nuts until lift is completely assembled.**

#1 Slide BB parts on uprights as shown.

#2 Insert four C parts (legs) into part A (v-side) and part B (regular side) as shown. Use one 3/8" x 3 1/2" pin and pin clip for each leg.

#3 Place A part (v-side) and B part (regular side) about nine feet apart as shown. Attach one D part (bottom beam) to *front* of A & B parts as shown. Attach with 3/8" x 4" hex bolt with 3/8" nuts at each connection.

Note: Bolt only five of the six holes at each corner at this time. The remaining hole will be used in a later step. See drawing for the one connection hole (in each front corner) not used at this time.

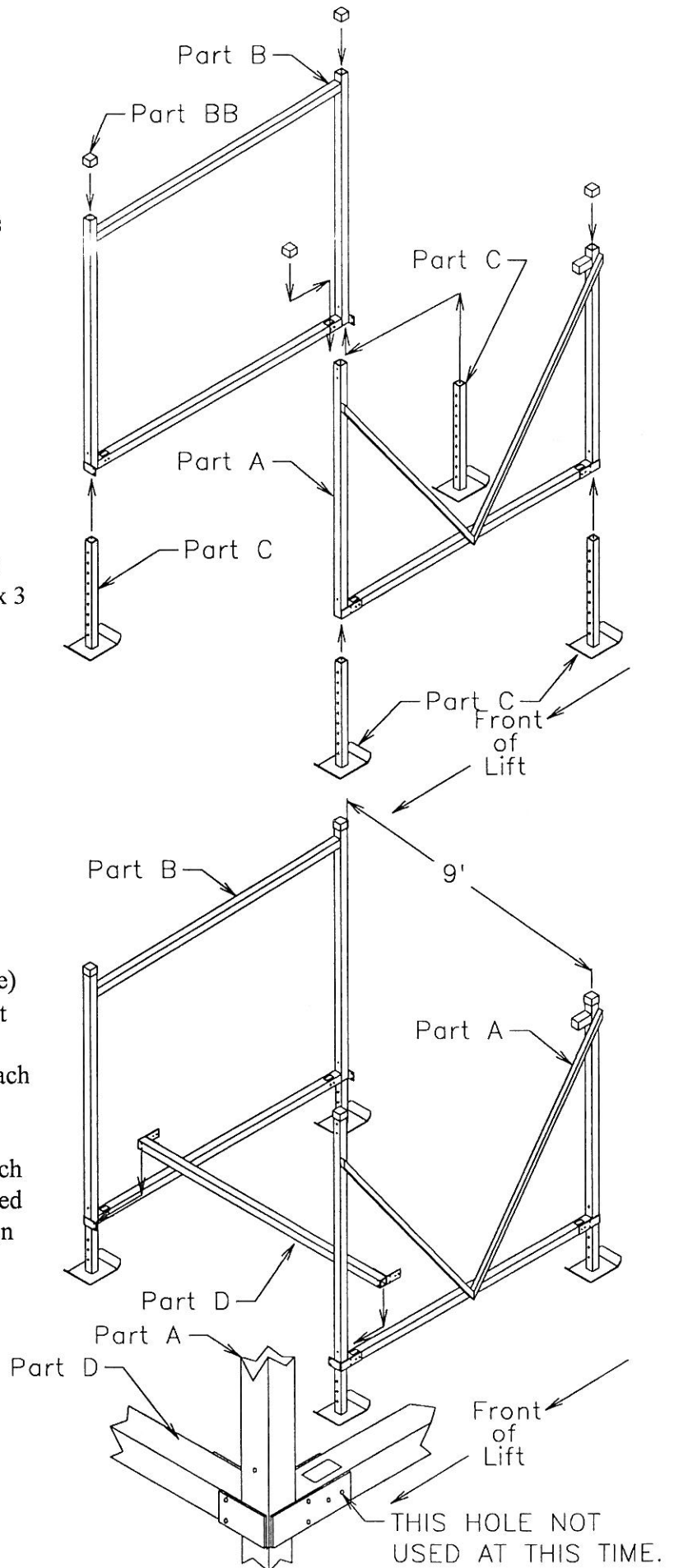

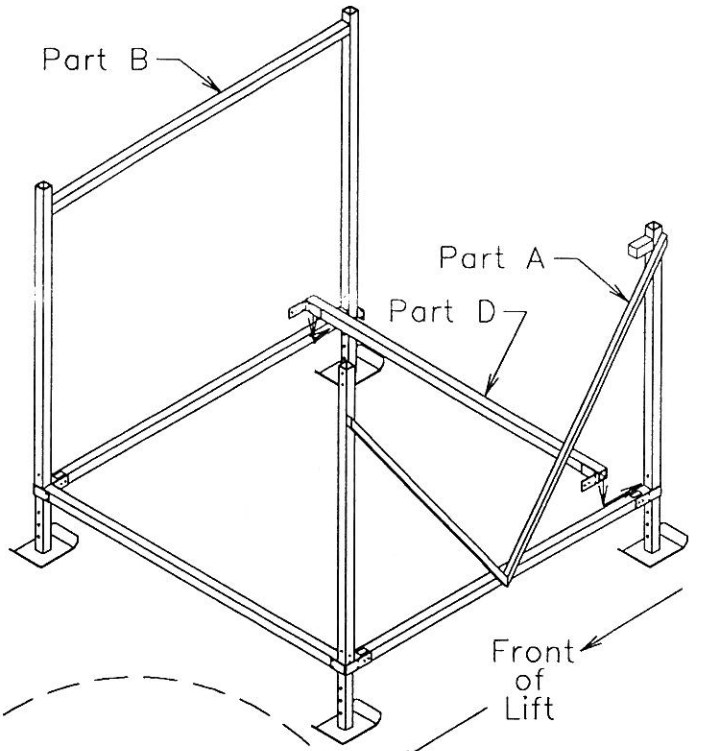

#4 Attach one D part (bottom beam) to rear of A & B parts as shown. Attach with five 3/8" x 4" hex bolts and 3/8" nuts at each end.

Note: Bolt only five of the six holes at each corner at this time. The remaining hole will be used in a later step. See drawing for the one connection hole (in each rear corner) not used at this time.

Note: The holes not used (in each rear corner) are different than those in last step. See drawing.

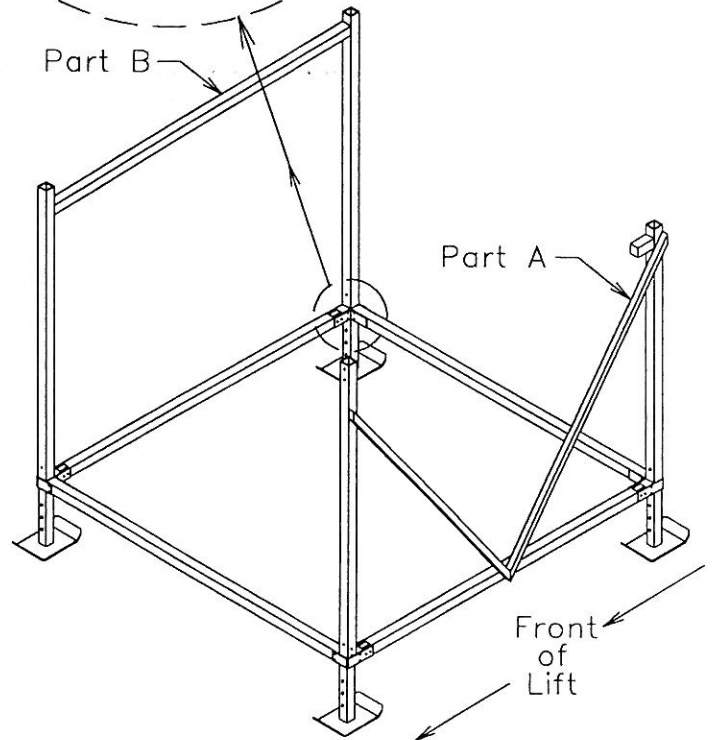
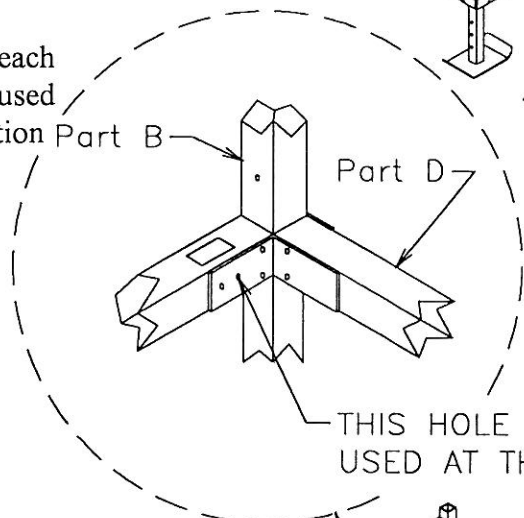

#5 Set part E (left rack) in area shown. Place end with cable loop into position. Secure cable loop using open hole in part A (V-side) with 3/8" x 3 1/2" pin and pin clip.

Note: This completes the connection process in that corner for part A and part D (bottom beam).

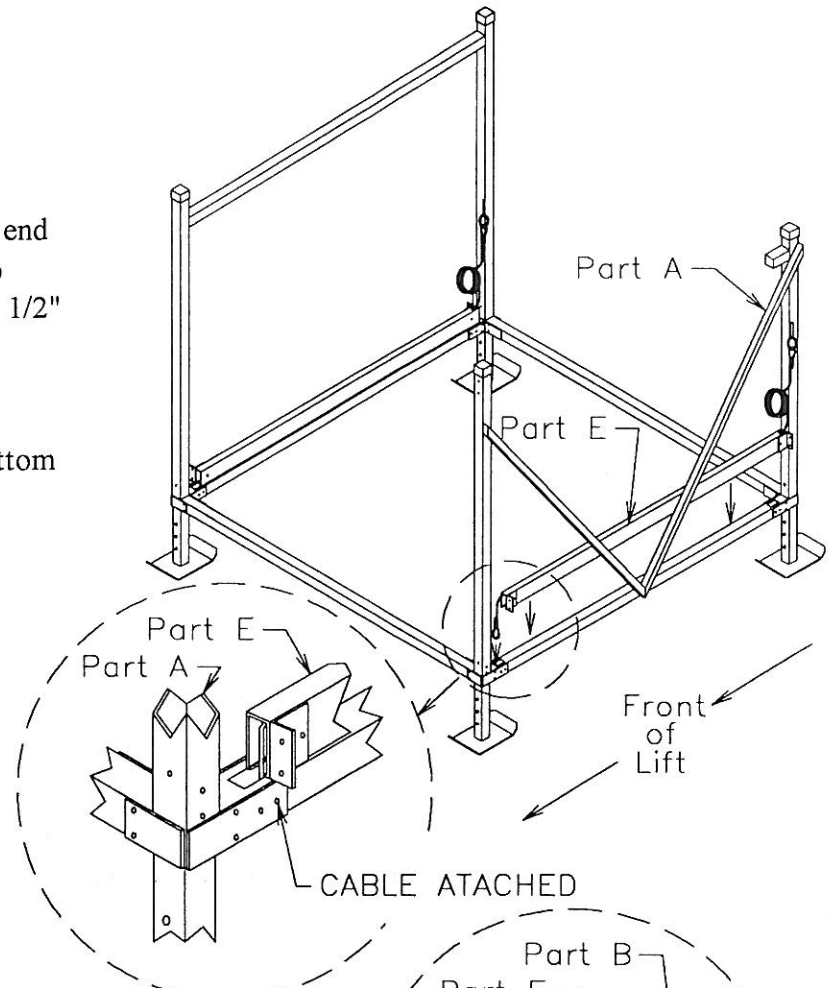

#6 Set part F (right rack) in area shown. Place end with cable loop into position. Secure cable loop using open hole in part B (regular side) with 3/8" x 3 1/2" pin and pin clip.

Note: This completes the connection process in that corner for part B and part D (bottom beam).

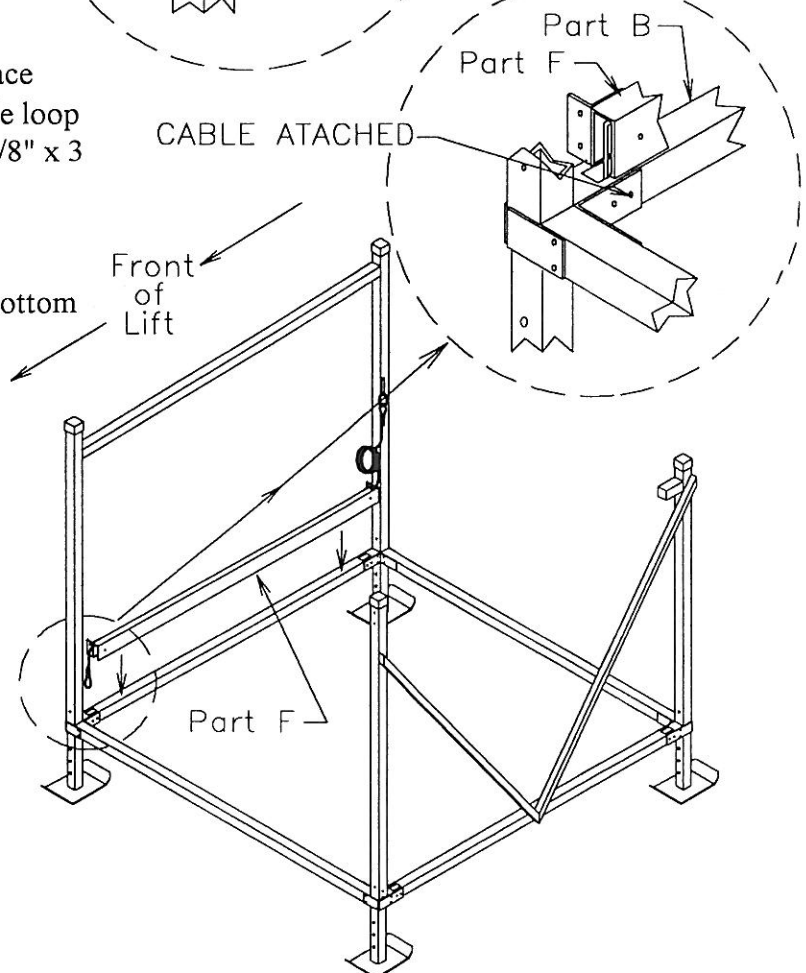

#7 Set part G (rear rack) in area shown. This part has two cables contained within. Place each cable loop into position as shown.

-Secure one cable loop using open hole in part A (V-side) and opposite cable loop in open hole in part B (regular side). Use 3/8" x 3 1/2" pin and pin clip.

Note: This completes the connection process in this corner for part A and part D (bottom beam).

Note: This completes the connection process in this corner for part B and part D (bottom beam).

#8 Attach part G to part E & F (rack sides). Use two 3/8" x 1" hex bolts and 3/8" nuts at each end.

#9 Place part H (front rack) in area as shown. Attach part H to part E & F (rack sides). Use two 3/8" x 1" hex bolts and 3/8" nuts at each end.

#10 Attach the I-bolts with cables to the proper holes in your part A & B sides as shown. Slide I-bolt into position. Attach a 1/2" lock nut and washer, located in bolt bag, to each I-bolt.

Note: Be sure washer is in place and that lock nut is tightened so at least 1/4" of I-bolt thread is exposed.

Note: There are five I-bolts to attach. See the drawing of I-bolts and cables on next page to ensure correct location.

CAUTION

Failure to attach cables, I-bolts, washers and lock nuts correctly could result in a severe crushing, cutting or pinching injury. Severe damage to lift or boat could also occur.

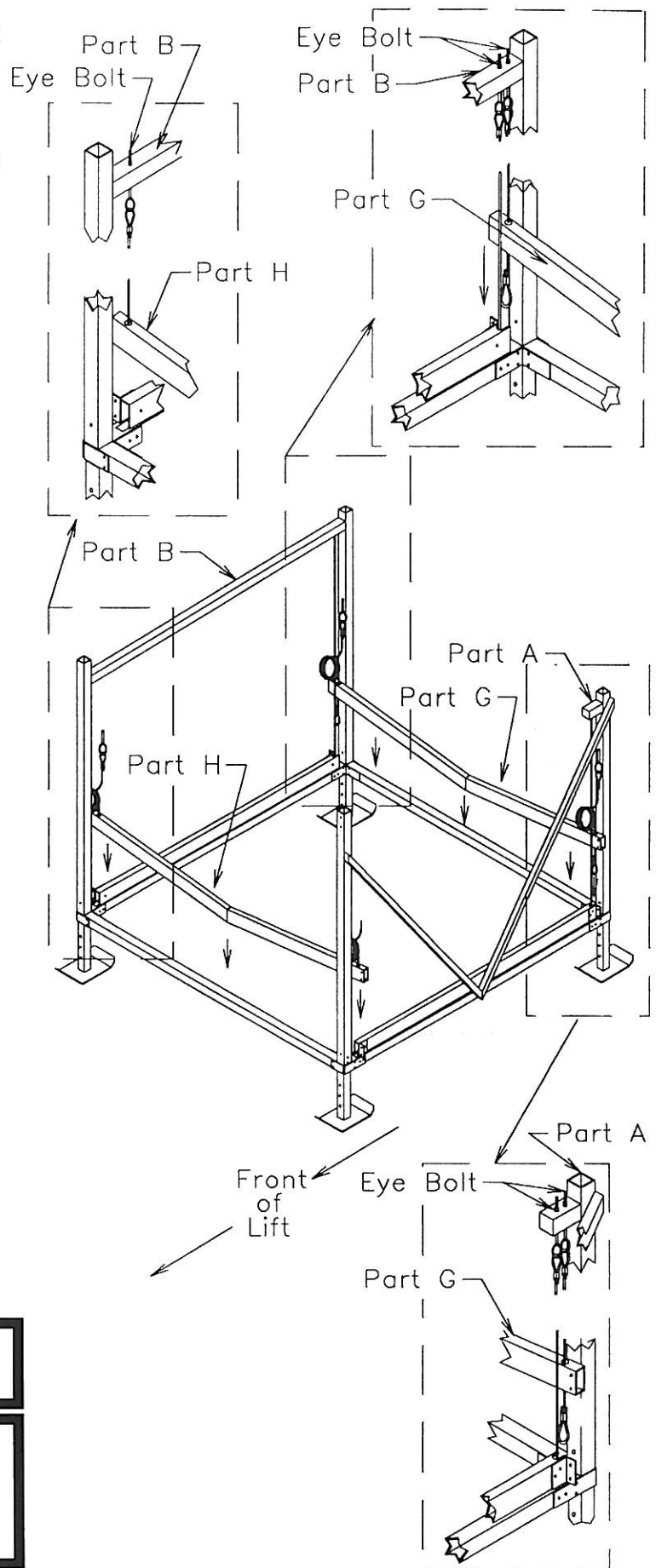

Assembly Showing proper cable location

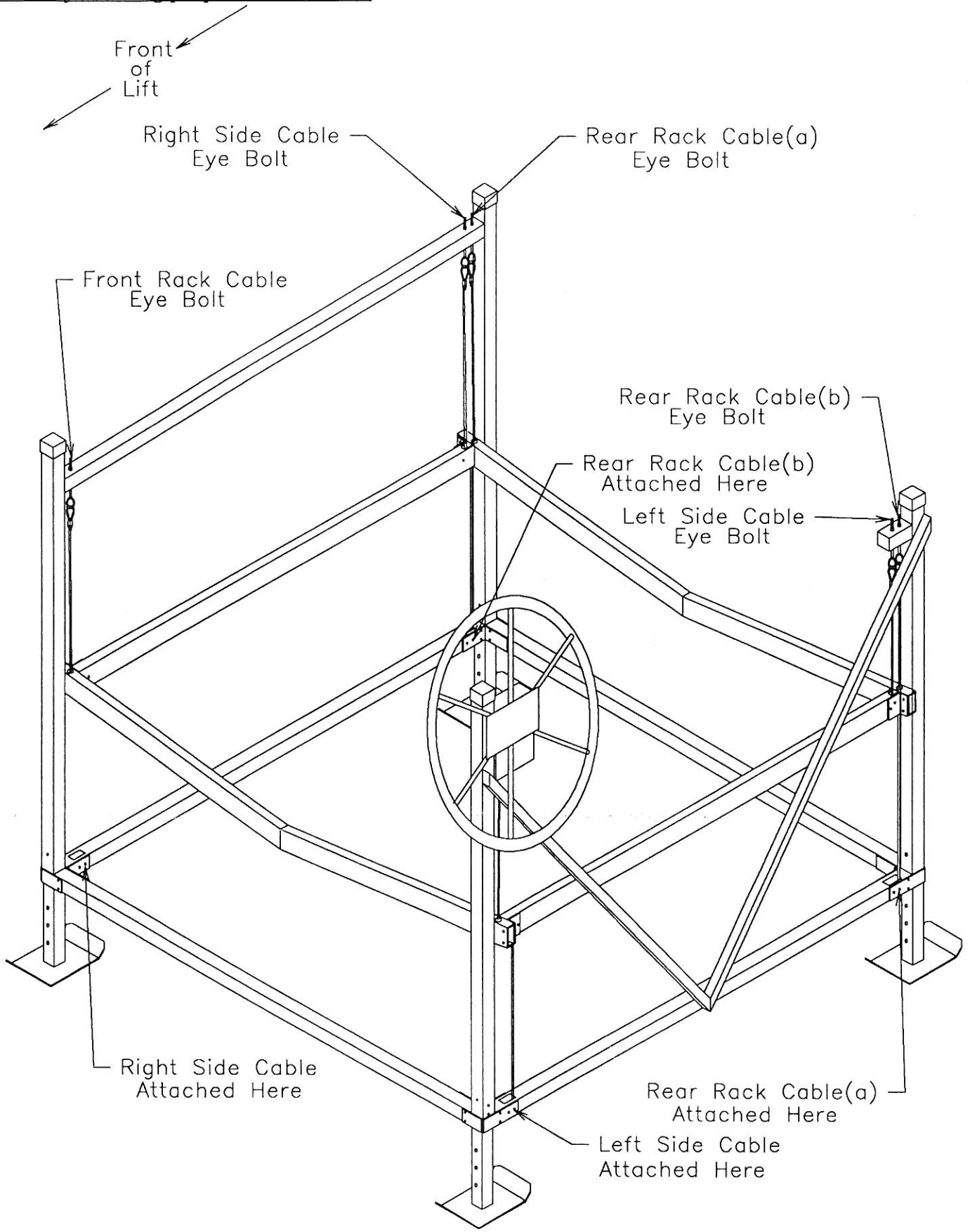

#11 Attach cable from H part to AA part (winch) as shown. Slide cable end into slotted opening in winch hub. Tighten winch hub set screw to secure cable to winch hub.

Note: Cable must enter at slotted end of opening through hub as shown.

Note: Slide cable fully into hub opening. However, do not go so far that it sticks out other side of hole. This would interfere with proper cable wrapping.

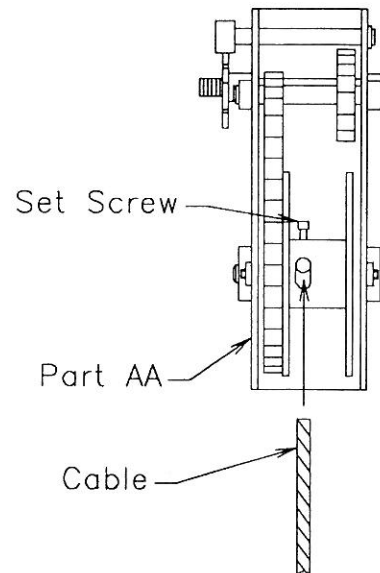

#12 Attach DD part (cable guide) to bottom of winch housing. Use the bolts and nuts that come attached to the cable guide. This guide prevents stacking of cable on winch hub.

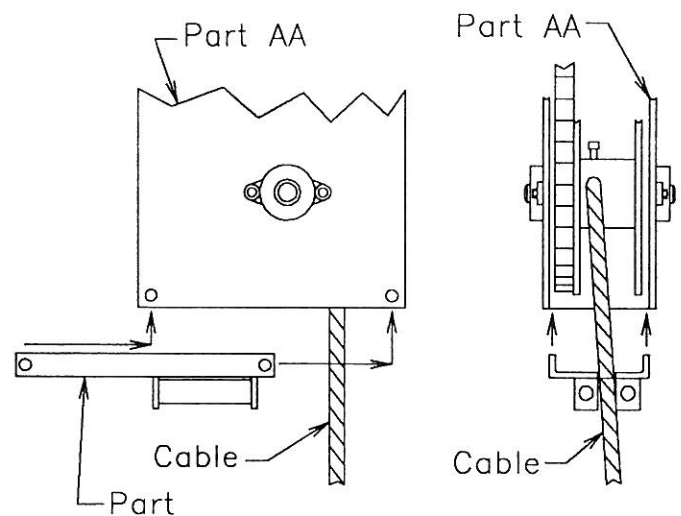

#13 Attach AA part (winch) to A part upright as shown. Use two 3/8" x 4" hex bolts, four 3/8" washers and two 3/8" nuts.

Note: You must remove winch cover to attach winch. Reattach cover when finished.

Note: Use two washers on each bolt. One against bolt head and one against nut.

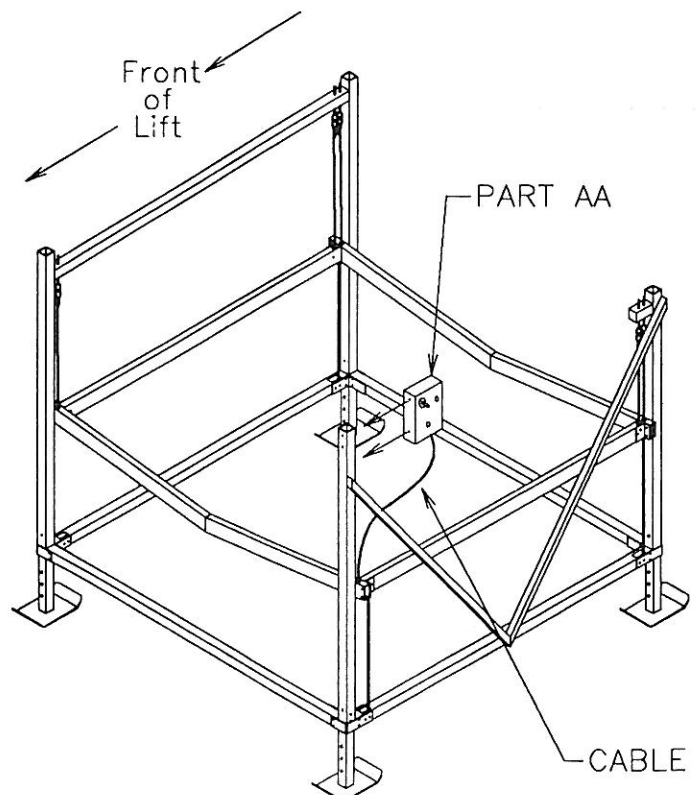

#14 Thread I part (wheel) clockwise on to shaft of AA part. Secure in place as shown by attaching 5/16" hex bolt, washer and spacer located in CC part bag.

Note: You will need to cut a small round hole in middle of wheel sticker to attach bolt.

Note: Do not over tighten this bolt. You could break bolt if you over tighten or cause the brake to function improperly.

Note: You must thread wheel all the way on winch shaft. The wheel hub must be up fully against brake pad and a clicking sound must be heard when turning wheel up!

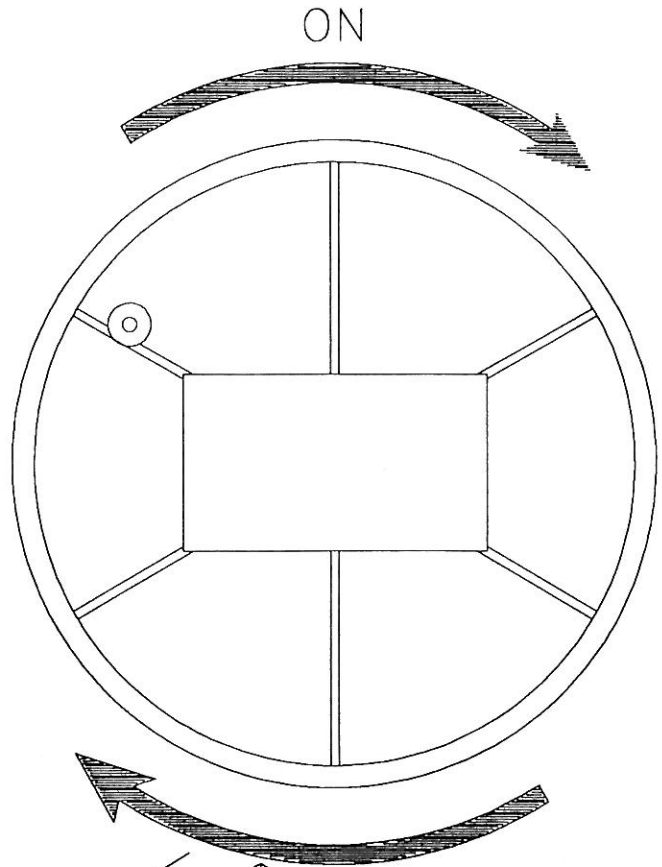

CAUTION

Be sure cable wraps tight and uniformly on hub. Do not allow cable to wind up loosely on hub. Cables wrapping incorrectly will result in rapid cable wear.

#15 Thread excess cable onto winch hub by turning wheel clockwise at this time. Applying tension to cable, by holding it tight when raising wheel, will help to develop proper wrap.

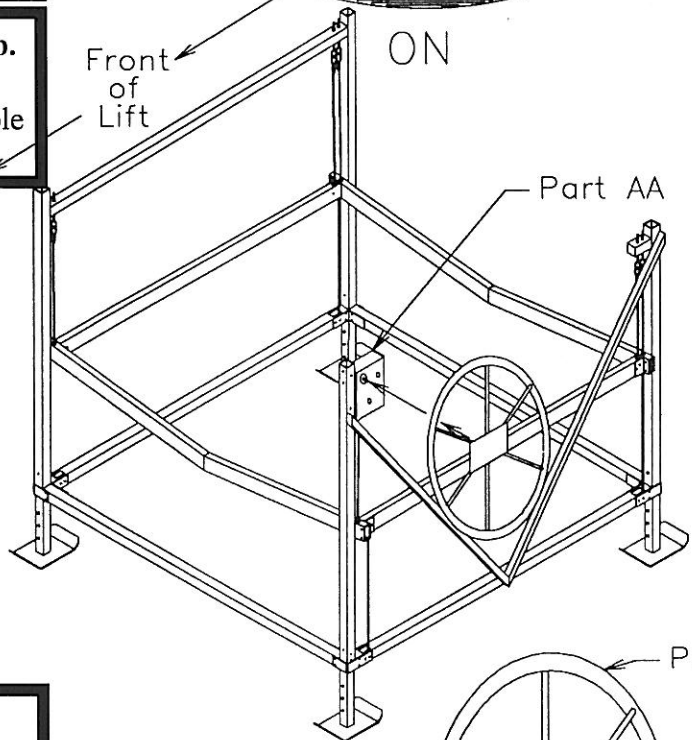

CAUTION

Use a leather glove or other hand protection to avoid cuts when applying cable pressure.

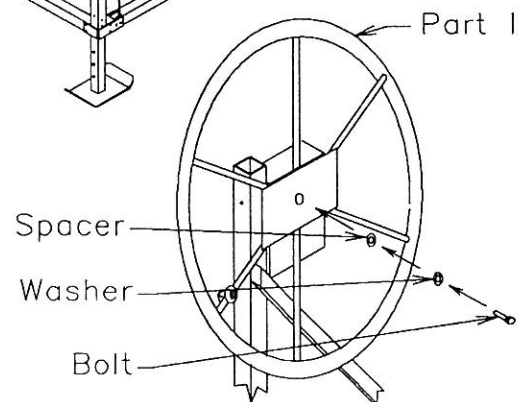

#16 Proper Cable Adjustment

- There are four cables with I-bolts and nuts that must be adjusted to properly level cables. These I-bolts are all located near the rear uprights as shown.
- Turn wheel so front rack beam raises about 6" above the bottom of frame. Adjust cables so all corners of rack are the same distance from frame.

Note: The nuts on I-bolts require adjustment to level your lift rack. Use the frame below the rack as your reference point. Measure the distance from frame to rack in each corner. These distances should all be within a 1/4 inch.

Note: Be sure washer is in place and that lock nut is tightened so at least 1/4" of I-bolt thread is exposed.

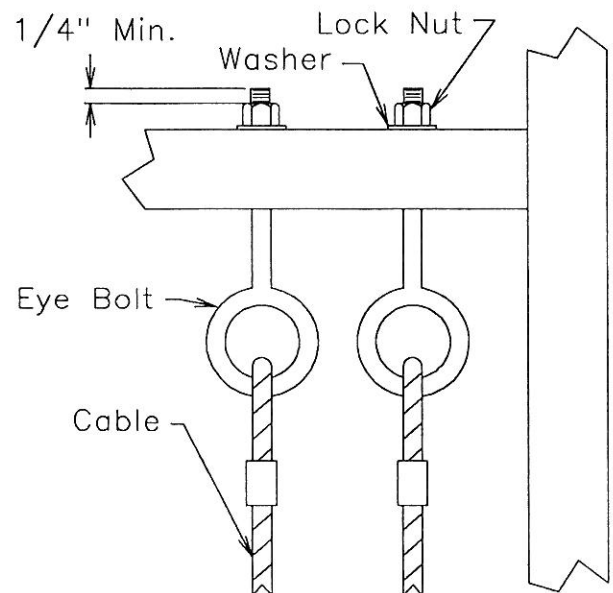
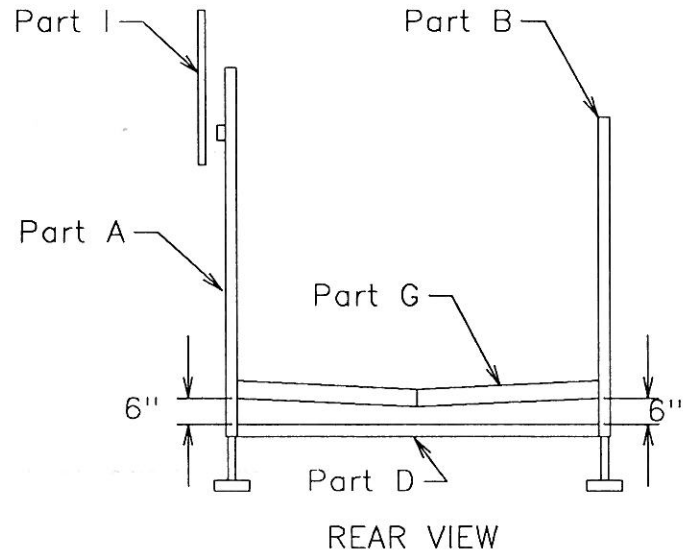
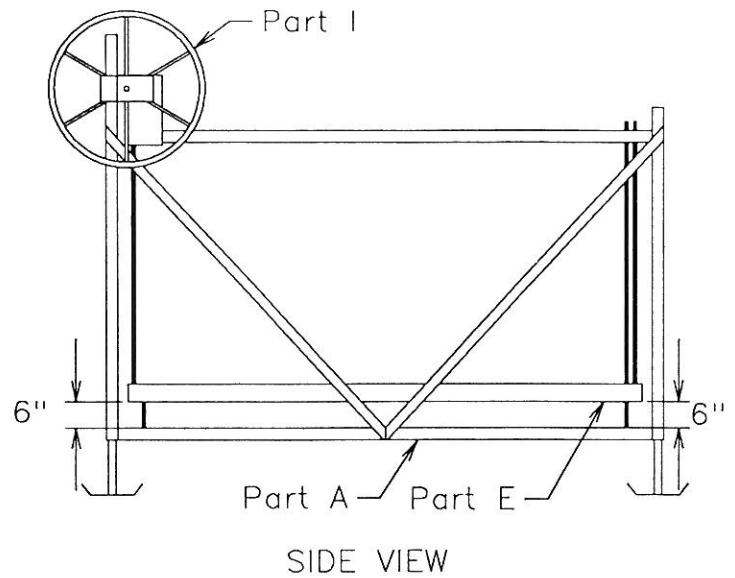

#17 Firmly secure bolts and nuts at this time.

#18 Many accessories are available for use with this boat lift. See assembly instructions for each required accessory. Follow relevant safety instructions mentioned in this manual when attaching accessories.

INSTALLATION

The following are guidelines or suggestions for installation. Situations vary between installation sites. Common sense may dictate that other factors be considered in your situation. Your site may not allow for some of our suggestions to be used or followed entirely. Do not, under any circumstances, endanger yourself or risk damage to lift or boat when installing.

CAUTION

If you are unable to properly and safely install this boat lift, **please have a trained boat lift installer perform the installation.**

#1 Measure water depth of exact position you want to locate lift.

#2 Before installing, adjust lift legs so lift can be properly positioned in water.

Note: Lift must be positioned low enough so boat can float into position before raising, while also allowing high enough position so the boat can be fully raised up and out of water.

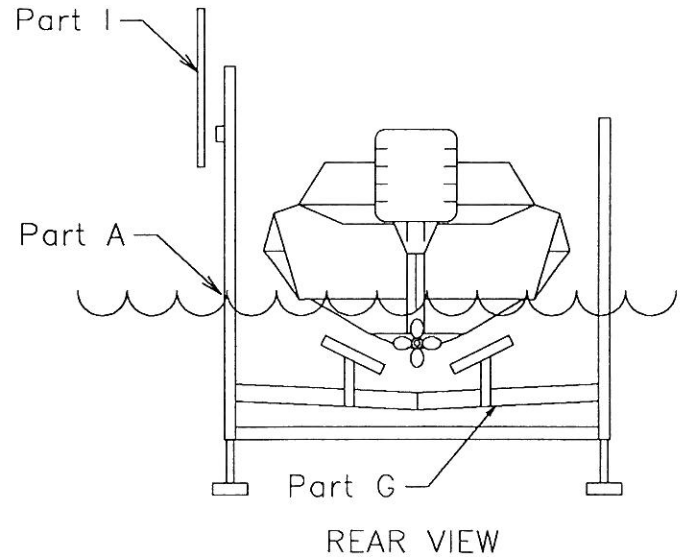

#3 Be sure lift rack is in fully lowered position. This will prevent rack from shifting when moving lift into position.

Note: Lift rack must always be in partially raised position before any weight is applied. Adjust lift legs down or move lift to deeper water if this cannot be accomplished!!!

CAUTION

Never apply weight on lift when top rack is in fully lowered position. Doing this will bend lift frame and cause permanent damage to lift.

CAUTION

A raised lift rack could cause a pinching or cutting injury during installation. Be sure lift rack is fully lowered when installing. Never move or carry your boat lift by grabbing the lift rack.

#4 Carry, lift, roll, float or slide lift into position. Position alongside dock so hand wheel can be easily turned from dock.

CAUTION

Lift must be resting on lake bottom in a level, secure and stable position for safe operation. An unstable lift installation could result in tipping of lift during operation, causing damage to watercraft, and crushing or pinching injury to operator.

OPERATION

-Loading of Watercraft-

WARRANTY DOES NOT
APPLY IF DAMAGE IS
CAUSED BY IMPROPER
LOADING!!

#1 Be sure lift rack and cradles or bunks are positioned below water surface so they will not interfere with boat floating into position.

CAUTION

Be sure boat is properly balanced and centered on lift before raising.

CAUTION

If lift is without a boat in it for more than one day, raise the rack (pulleys) fully out of the water to help prevent corrosion of these parts.

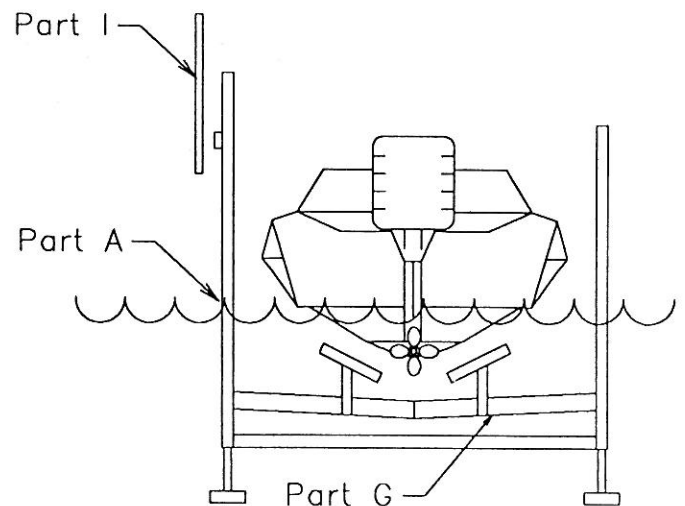

REAR VIEW

#2 Position boat with center of gravity near middle of lift. For most rear engine mounted boats, this requires you to position the boat mostly forward in the lift.

-Raising Lift-

#1 Make sure craft is in proper position. Turn lift wheel clockwise (in direction of up arrow). Stop turning wheel when boat reaches desired height out of the water.

WARNING

Stay clear of lift (facing wheel) while operating. Do not allow anyone on, in or under lift. A cable or lift part failure can cause a sudden drop of boat, resulting in a crushing or falling injury or death!

CAUTION

Turn wheel in direction of arrow (clockwise) to raise lift. A clicking sound is heard when properly raising lift. Turning wheel and wrapping cable in wrong direction will cause fast spin down of wheel.

CAUTION

If fast spin down of wheel occurs do not touch wheel or attempt to stop. Placing hands or feet on spinning wheel can cause broken or cut limbs.

CAUTION

Properly cover your boat, when in raised position, if rain can gather in your craft. An inch of rain adds several pounds to lift. Added weight may result in boat being over capacity.

CAUTION

Do not over raise lift rack. Stop before top of rack hits cable loops attached to I-bolts. Over raising could cause damage to winch, cables or other parts.

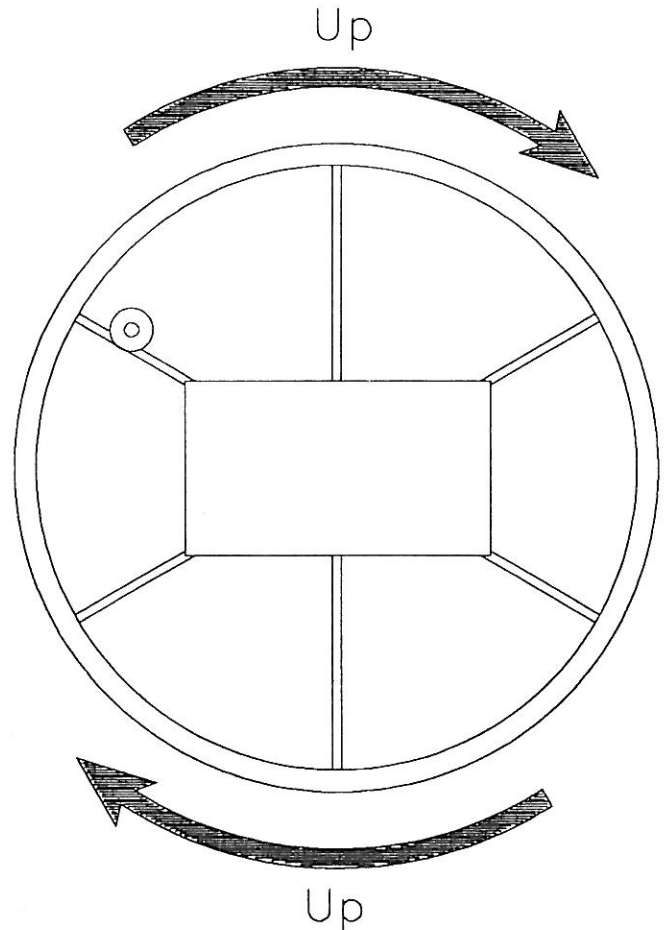

#2 Optional: Lock and chain wheel for security.

CAUTION

Do not allow people on boat when in a raised position on lift. Entering boat when in the raised position adds to lift load and is not safe! A falling injury could occur should lift fail.

CAUTION

Do not allow anyone who is in the water within six feet of the lift. A crushing injury could occur to swimmer should cable, winch brake or lift part fail.

-Lowering Lift-

#1 Turn wheel counterclockwise (in direction of down arrow).

Note: Turn wheel down one or two turns past point when craft begins to float (This must always be at some point before lift rack is contacting rear bottom beam). Then turn wheel up slightly until clicking sound is heard to secure wheel position and brake on winch.

CAUTION

Winch Safety - Never disconnect ratchet pawl, gear or brake mechanism to lower lift wheel. Disconnected or faulty brake parts will result in rapid spinning of wheel.

CAUTION

Do not over lower wheel so slack develops in cable. Doing this could cause cable to jump off winch spool. This may result in sloppy wrapping of cable next time you raise the lift, resulting in premature wear or cable breaking.

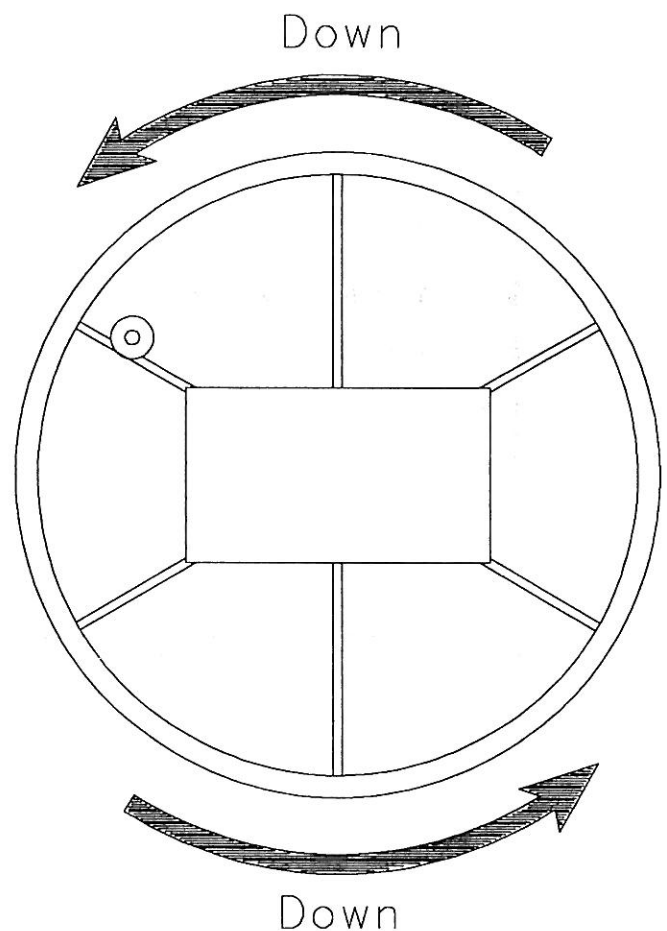

REMOVAL & STORAGE (winterizing)

****ShoreMaster does not warrant this product against any damage caused by or related to ice!!**

CAUTION

Ice can severely damage your boat lift. Do not leave lift, or boat on lift, in water if ice damage is possible.

#1 Be sure lift rack is in fully lowered position. This will prevent rack from pivoting when moving lift out of water.

CAUTION

A raised lift rack could cause a pinching or cutting injury during removal. Be sure lift rack is fully lowered when removing. Never move or carry your boat lift by grabbing the lift rack.

#2 Carry, lift, roll, float or slide lift out of water. Position safely away from potential ice build up.

SERVICE (Maintenance)

#1 Inspect nuts and bolts at least every six months for damage, wear or loose connections. Tighten or replace parts as needed.

CAUTION

Check cables for frays, corrosion or breaks at least once a month. A cable breaking while boat is in lift could damage boat or lift. Severe bodily injury could also occur.

#2 Inspect lift frame, pulleys, winch and pivot points at least every six months for unusual wear, damage or bent parts. Replace or repair as needed.

#3 At least every six months, check that the rack is level with the bottom frame of your lift. Cable stretching or settling of lift could require you to adjust nuts on I-bolts.

#4 Lubricate winch and wheel threads at least every six months.

Note: Do not get lubricant on brake pads! Brake will fail and wheel will spin down if brake pads are lubricated.

#5 Lubricate pulleys at least every six months.

#6 ShoreMaster dealers usually offer service visits. Please contact them if you are unable or unwilling to perform maintenance or service to lift.

***** The following page shows cable placement and location in all rack beams.**

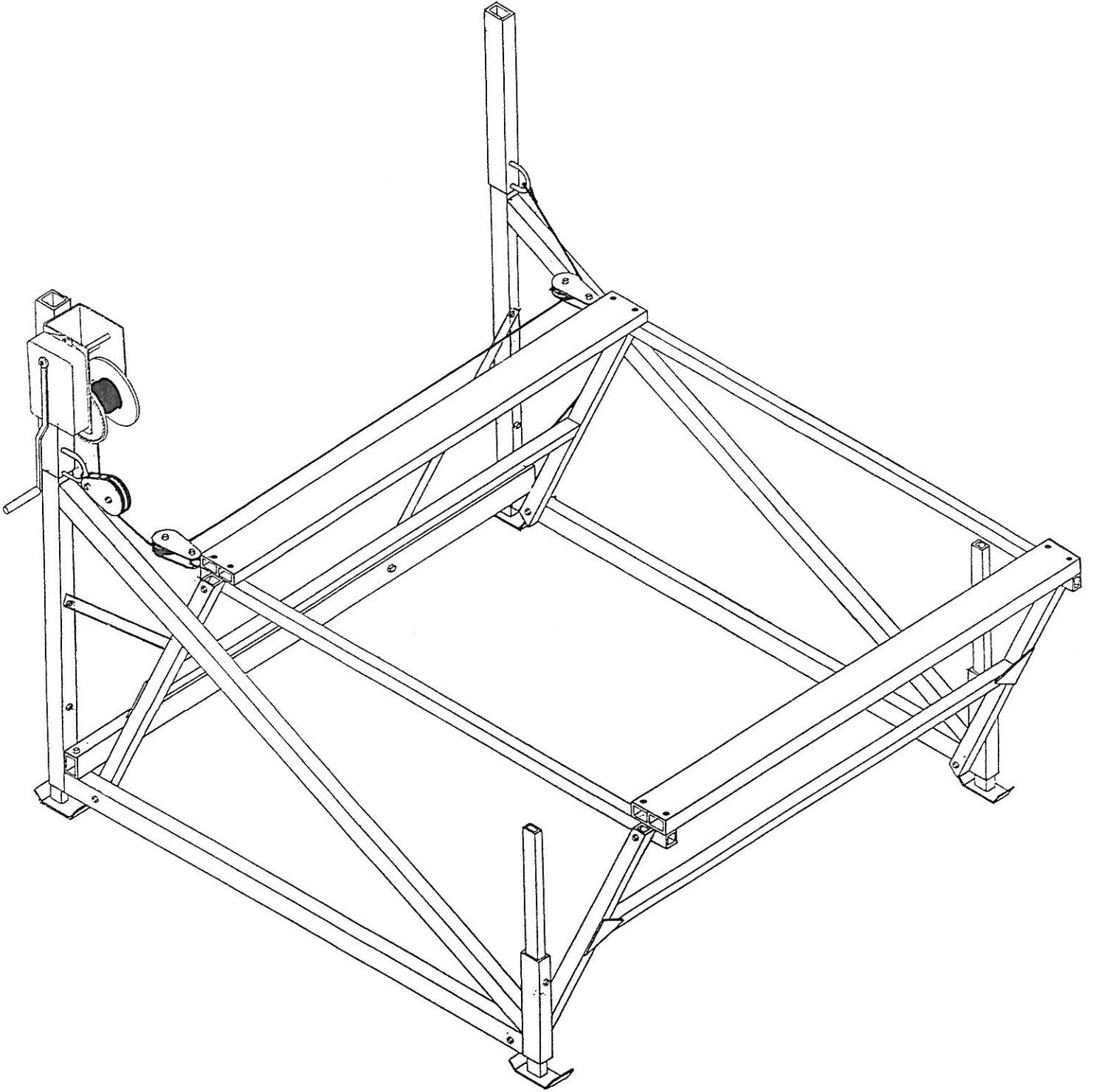

REMOVAL & STORAGE (winterizing)

****ShoreMaster does not warrant this product against any damage caused by or related to ice!!**

CAUTION

Ice can severely damage your boat lift. Do not leave lift, or boat on lift, in water if ice damage is possible.

#1 Be sure lift rack is in fully lowered position. This will prevent rack from pivoting when moving lift out of water.

CAUTION

A raised lift rack could cause a pinching or cutting injury during removal. Be sure lift rack is fully lowered when removing. Never move or carry your boat lift by grabbing the lift rack.

#2 Carry, lift, roll, float or slide lift out of water. Position safely away from potential ice build up.

